

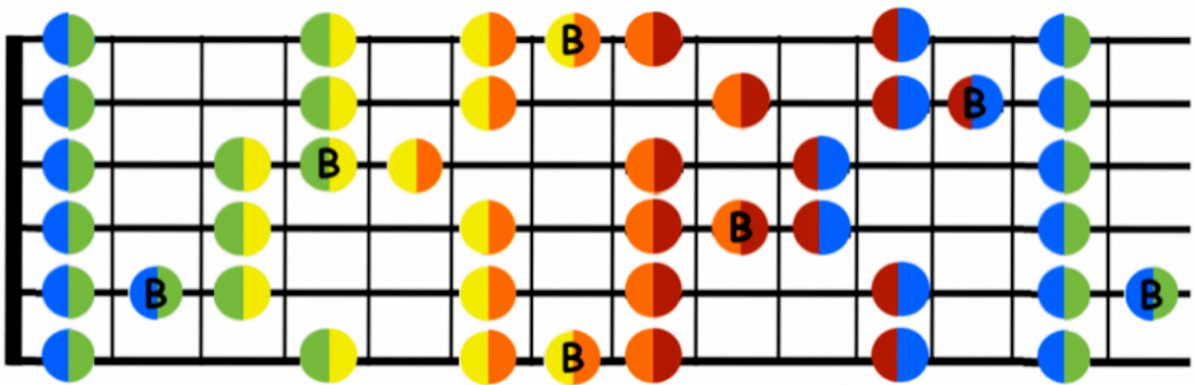

# *El Libro de las Escalas*



## **5 ESCALAS** por tonalidad

Mayor/Menor

Blues

Flamenco



# Índice

<b>Esquemas generales</b>	<b>3</b>
Escalas mayores/menores	3
Escalas pentatónicas (Blues)	4
Escalas armónica menores (Flamenco)	5
<b>Escalas por tonalidad</b>	<b>6</b>
Escalas de Do	6
Escalas de Do# / Reb	7
Escalas de Re	8
Escalas de Re# / Eb	9
Escalas de Mi	10
Escalas de Fa	11
Escalas de Fa# / Solb	12
Escalas de Sol	13
Escalas de Sol# / Lab	14
Escalas de La	15
Escalas de Sib / A#	16
Escalas de Si	17

# Escalas mayores y menores

Esquema 1

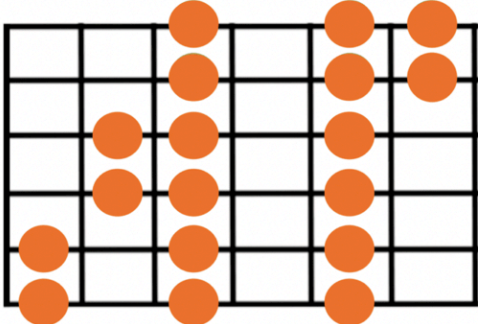

Esquema 2

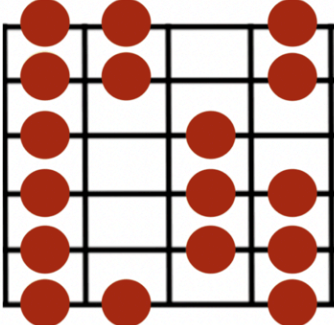

Esquema 3

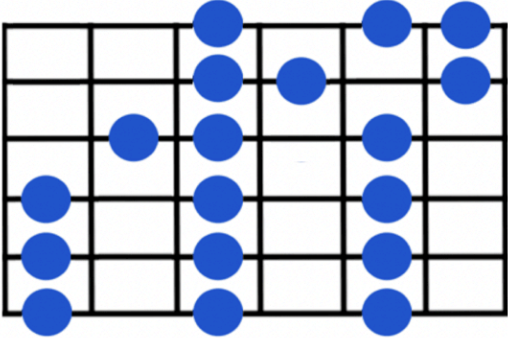

Esquema 4

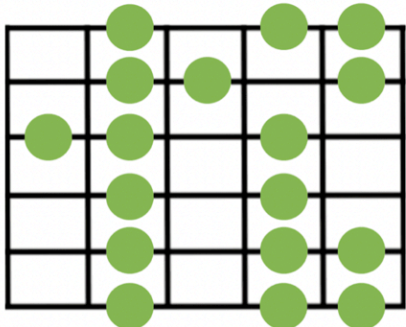

Esquema 5

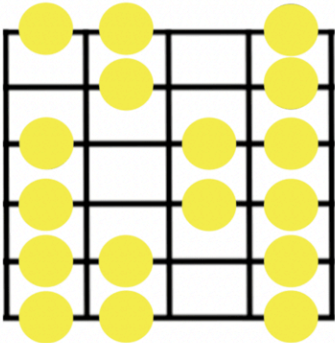

# Escalas pentatónicas (Blues)

Esquema 1

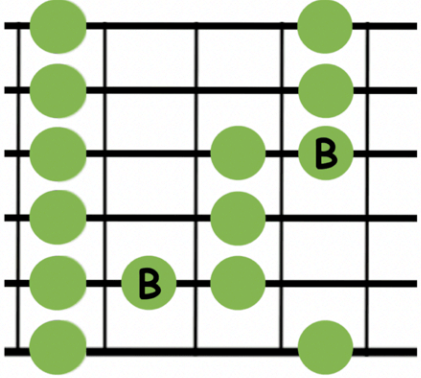

Esquema 2

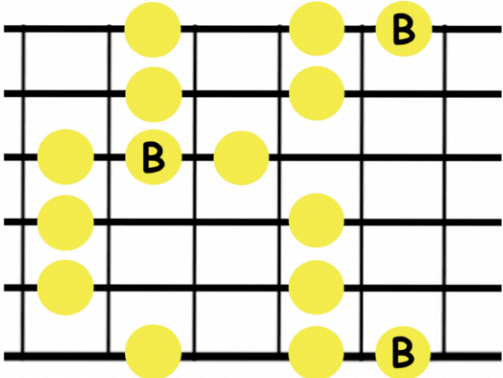

Esquema 3

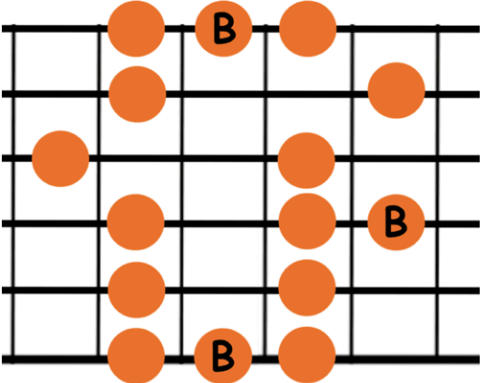

Esquema 4

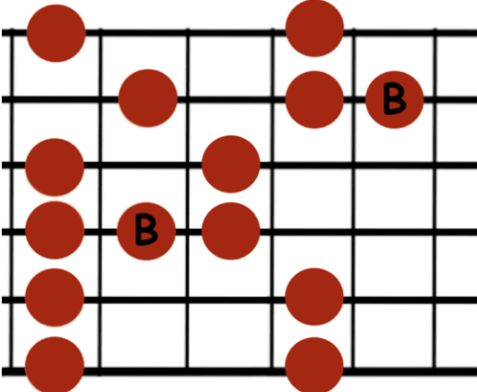

Esquema 5

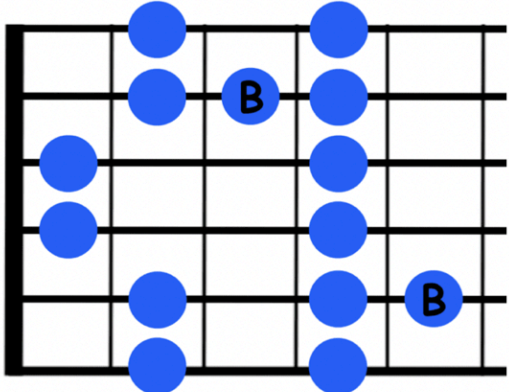



# Escalas menor armónica (Flamenco)

Esquema 1

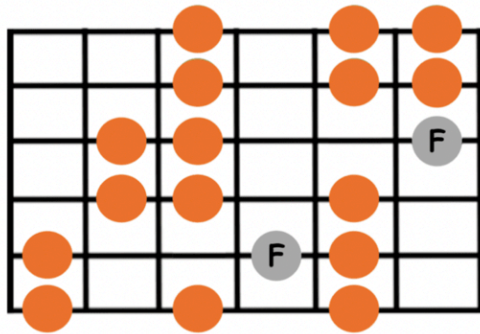

Esquema 2

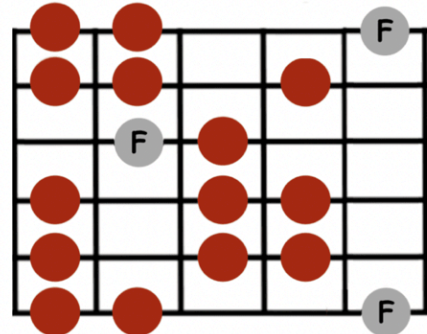

Esquema 3

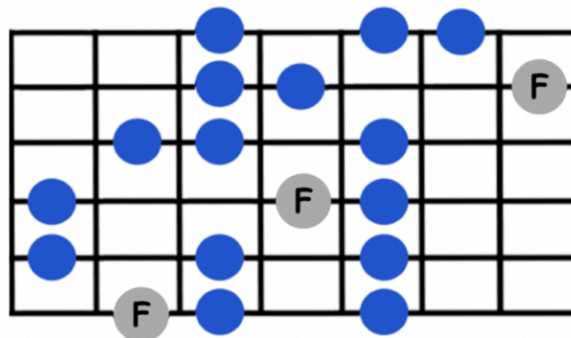

Esquema 4

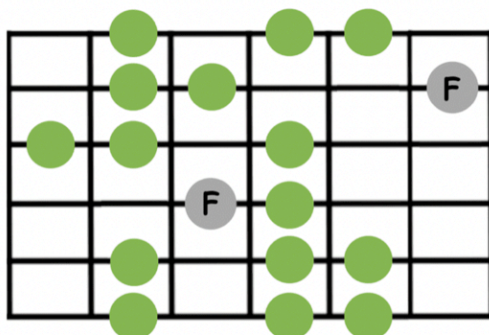

Esquema 5

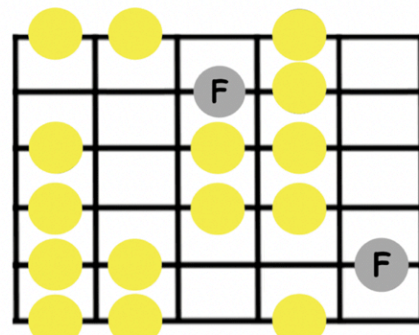

# Do / C

## Do mayor

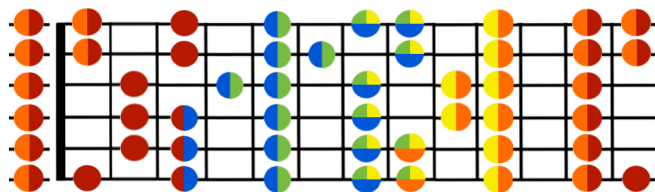

## Do menor (natural)

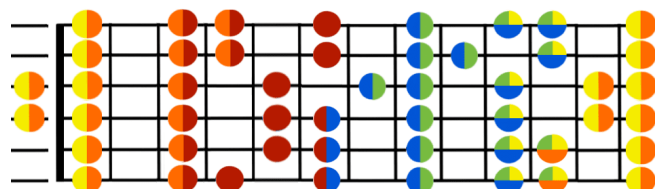

## Do blues (pentatónica)

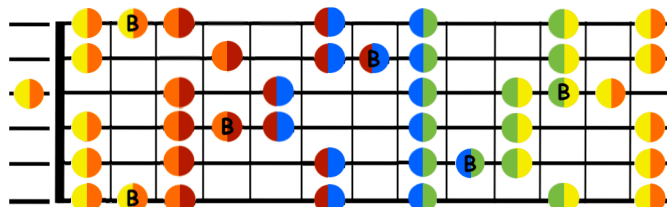

## Do mayor Flamenco (menor armónica)

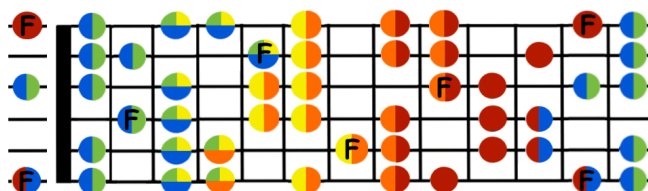

## Do menor Flamenco (menor armónica)

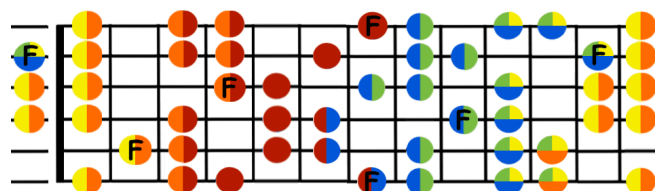

Do# / C#

Reb / Db

Do sostenido mayor

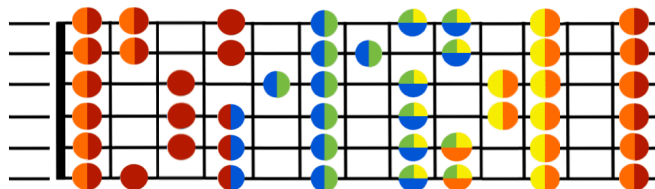

Do sostenido menor (natural)

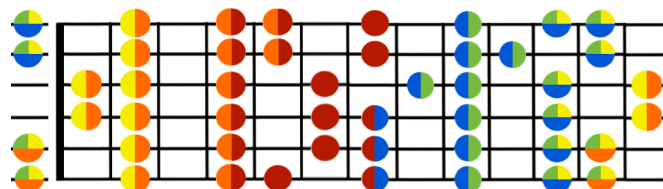

Do sostenido blues (pentatónica)

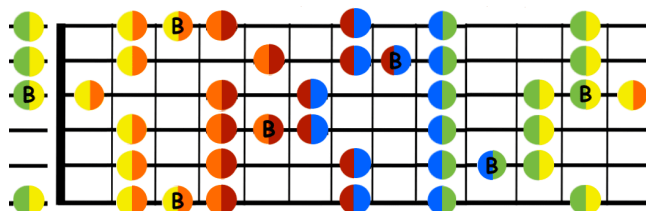

Do sostenido mayor Flamenco (menor armónica)

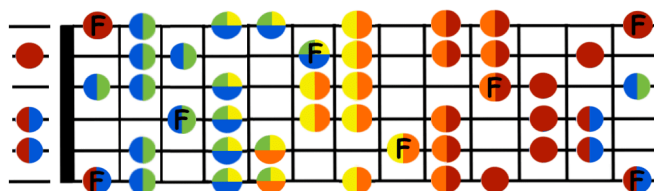

Do sostenido menor Flamenco (menor armónica)

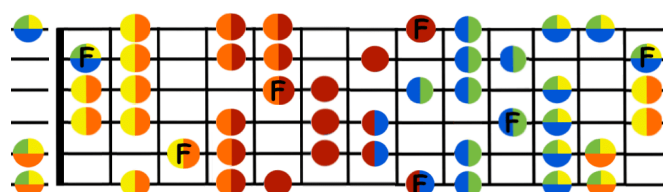

# Re / D

## Escala de Re mayor

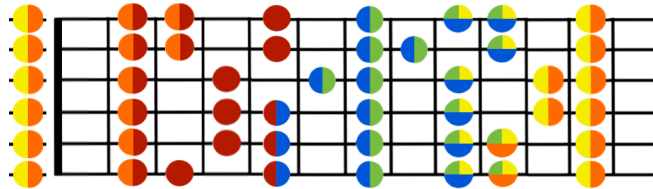

## Escala de Re menor (natural)

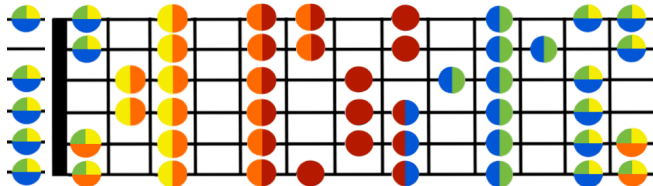

## Re blues (pentatónica)

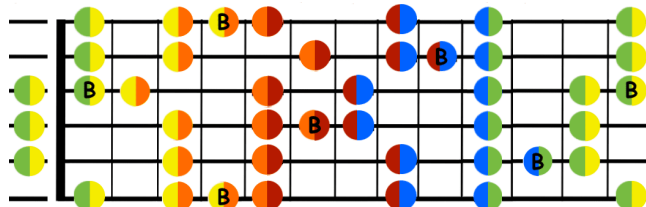

## Re mayor Flamenco (menor armónica)

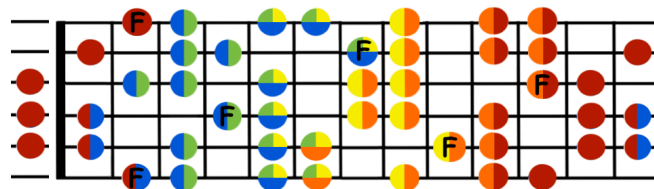

## Re menor Flamenco (menor armónica)

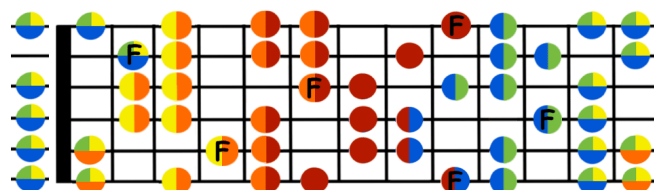



Re# / D#  
Mib / Eb

Re sostenido mayor

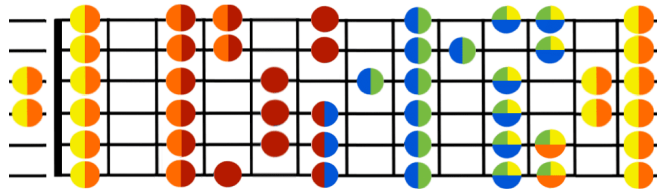

Re sostenido menor (natural)

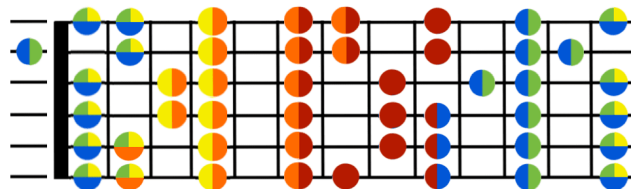

Re sostenido blues (pentatónica)

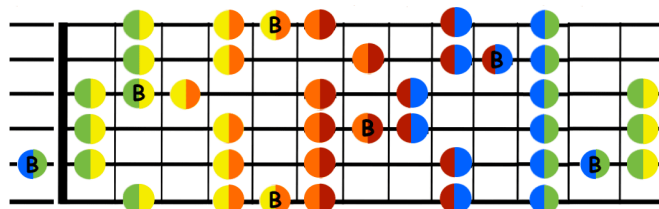

Re sostenido mayor Flamenco (menor armónica)

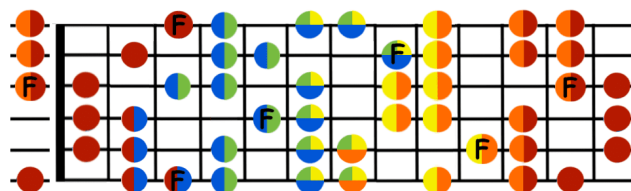

Re sostenido menor Flamenco (menor armónica)

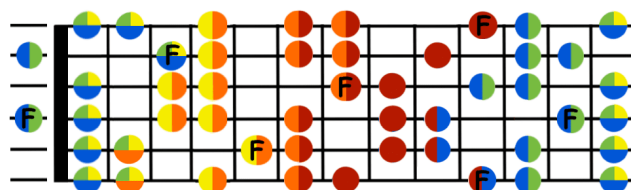

# Mi / E

## Mi mayor

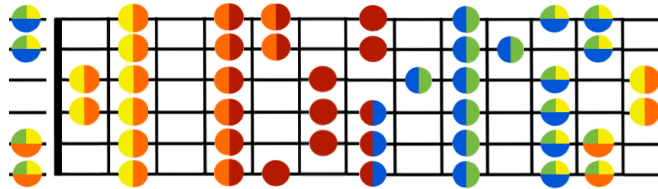

## Mi menor (natural)

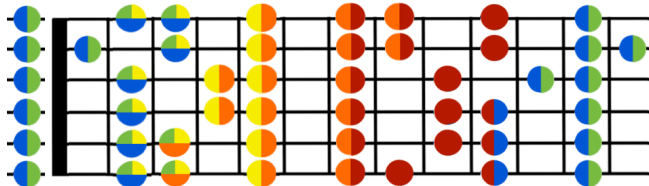

## Mi blues (pentatónica)

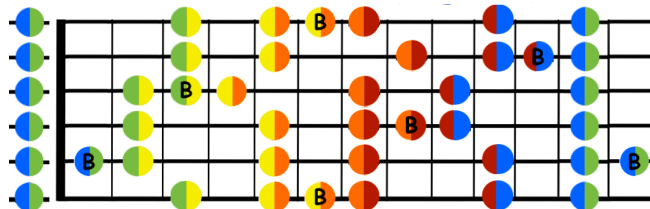

## Mi mayor Flamenco (menor armónica)

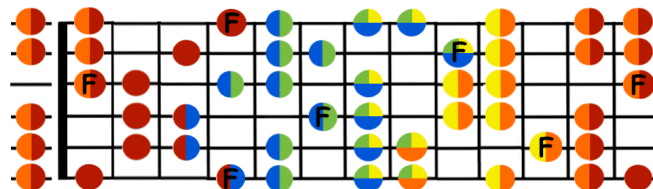

## Mi menor Flamenco (menor armónica)

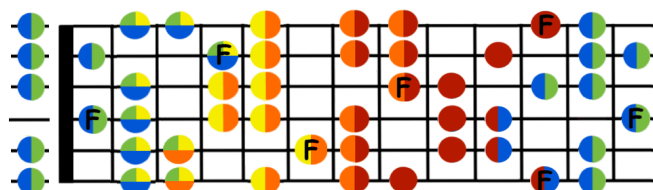

# Fa / F

## Fa mayor

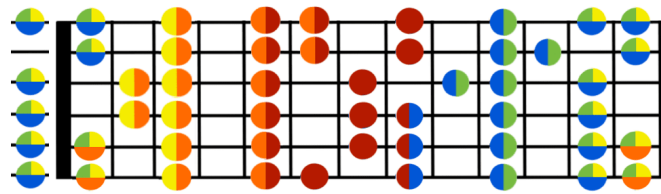

## Fa menor (natural)

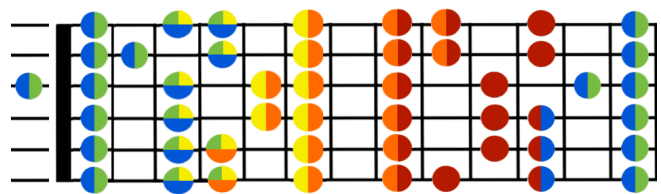

## Fa blues (pentatónica)

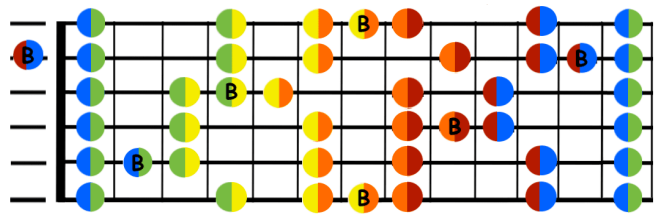

## Fa mayor Flamenco (menor armónica)

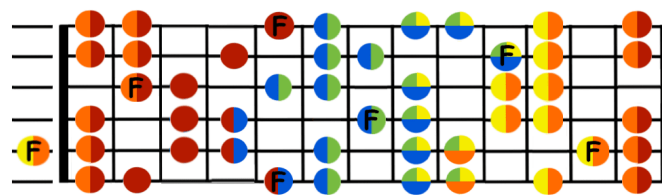

## Fa menor Flamenco (menor armónica)

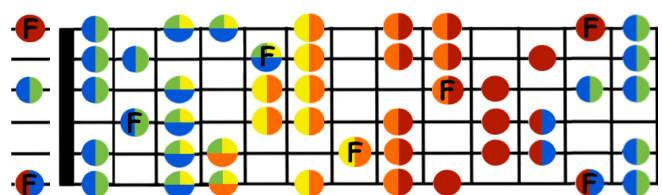

Fa# / F#  
solb / Gb

### Fa sostenido mayor

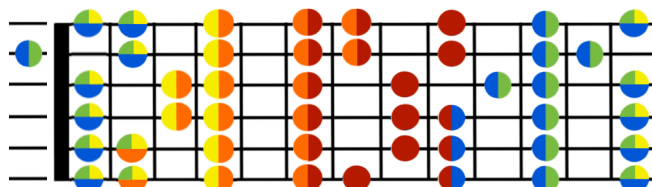

### Fa sostenido menor (natural)

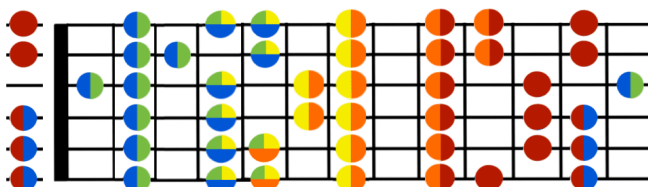

### Fa sostenido blues (pentatónica)

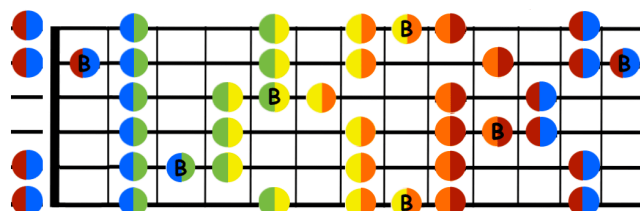

### Fa sostenido mayor Flamenco (menor armónica)

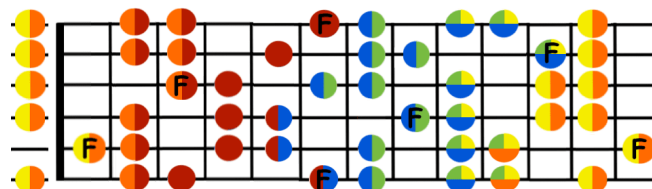

### Fa sostenido menor Flamenco (menor armónica)

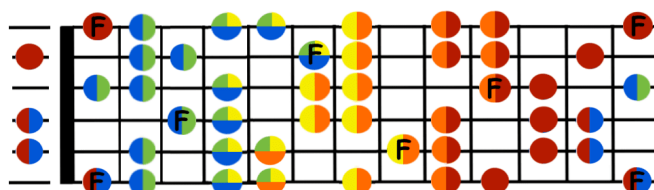

# Sol / G

## Sol mayor

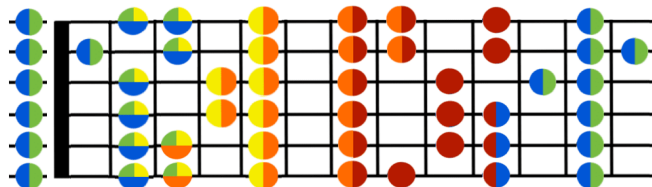

## Sol menor (natural)

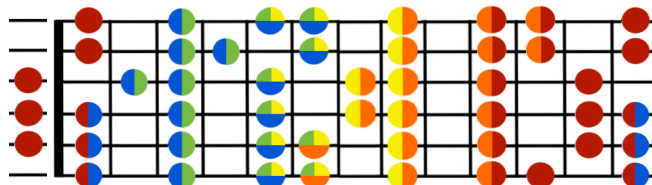

## Sol (blues)

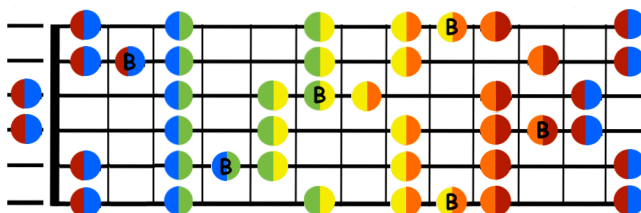

## Sol mayor Flamenco (menor armónica)

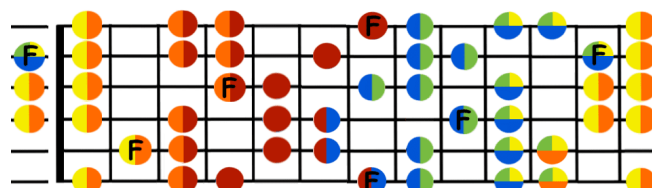

## Sol menor Flamenco (menor armónica)

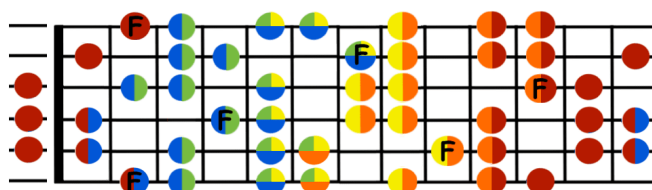



Sol# / G#  
Lab / Ab

### Sol sostenido mayor

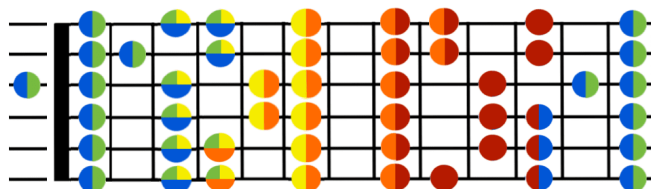

### Sol sostenido menor (natural)

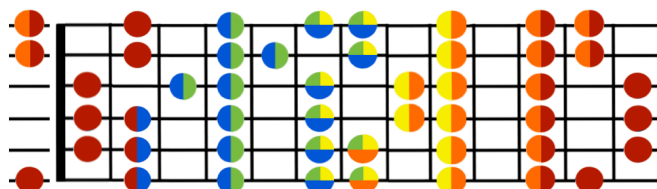

### Sol sostenido blues (pentatónica)

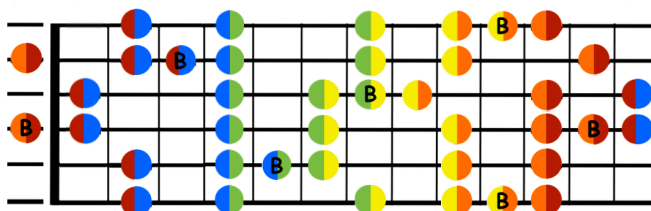

### Sol sostenido mayor Flamenco (menor armónica)

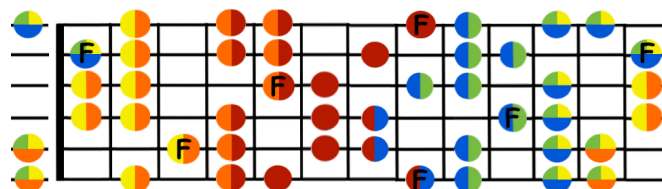

### Sol sostenido menor Flamenco (menor armónica)

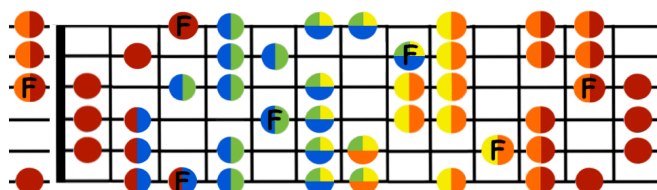

# La / A

## La mayor

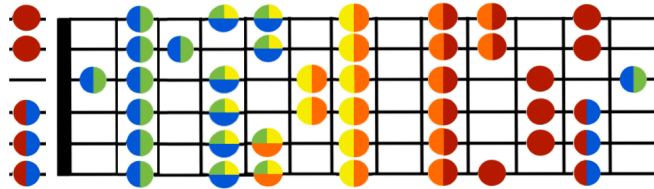

## La menor (natural)

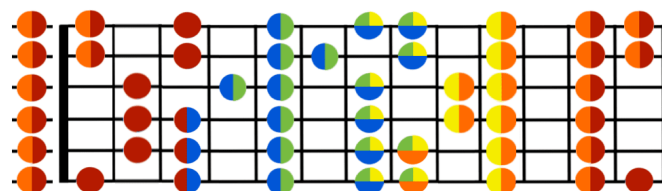

## La blues (pentatónica)

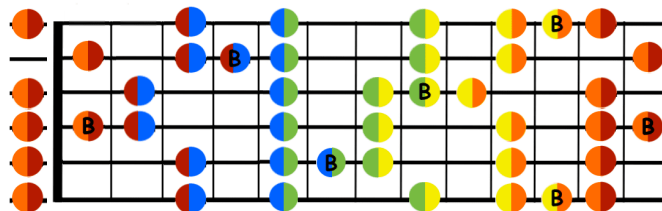

## La mayor Flamenco (menor armónica)

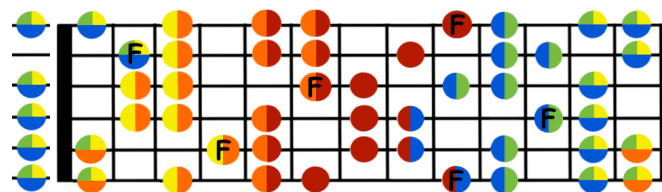

## La menor Flamenco (menor armónica)

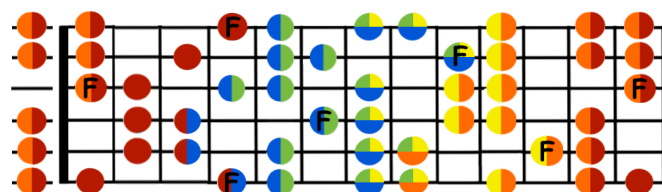

*Sib / Bb*

*La# / A#*

Si bemol mayor

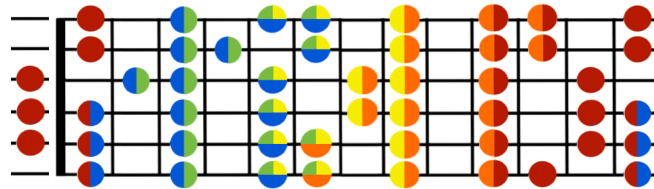

Si bemol menor (natural)

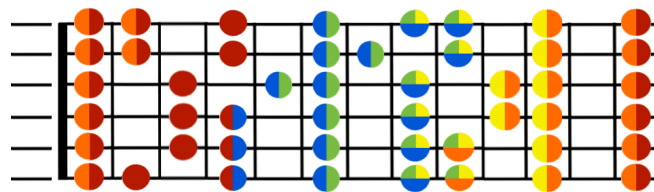

Si bemol blues (pentatónica)

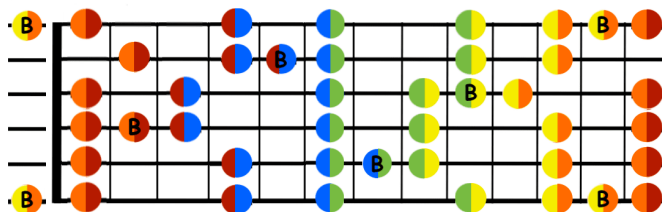

Si bemol mayor Flamenco (menor armónica)

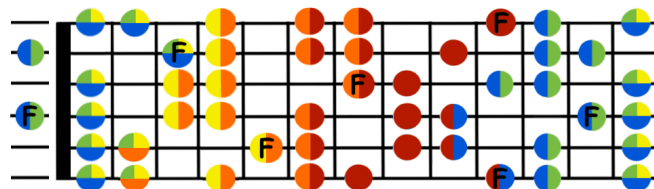

Si bemol menor Flamenco (menor armónica)

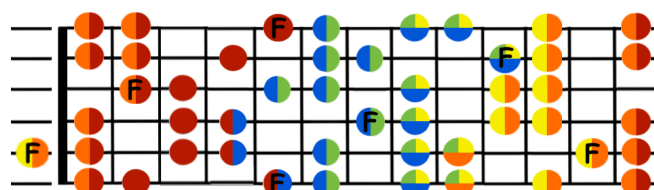

# Si / B

## Si mayor

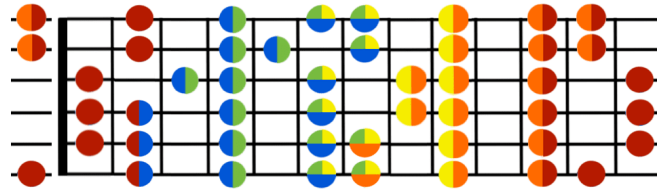

## Si menor (natural)

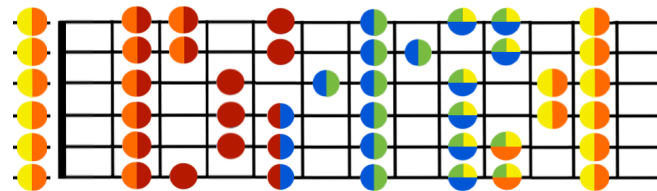

## Si blues (pentatónica)

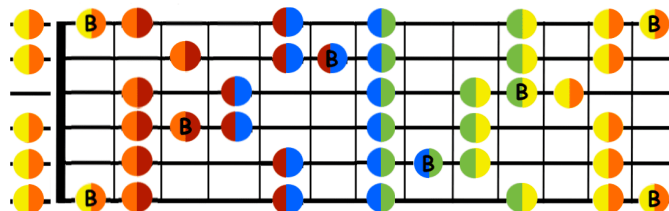

## Si mayor Flamenco (menor armónica)

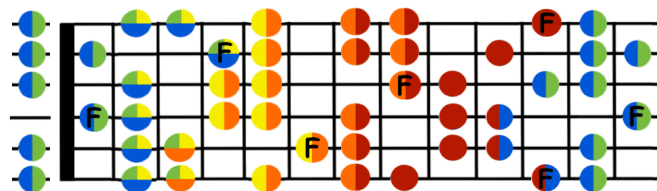

## Si menor Flamenco (menor armónica)

